

BH2 - BH10 Multi Bag Housings

296-1981
gpm
1500-7500
L/min

150 psi
10 bar

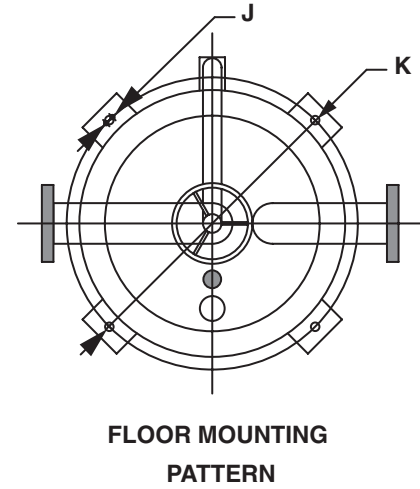
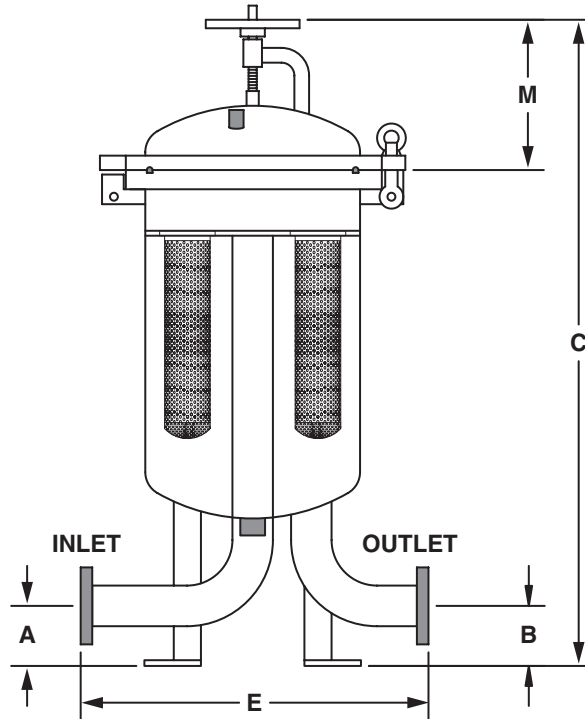

NOTE:
Drawings may change without notice. Contact factory for certified drawings.

Multiple Bag Housing Dimensions

Number of Bags	Available Porting (Flange)	A		B		C		E		øJ		øK		M	
		Inches	mm	Inches	mm	Inches	mm	Inches	mm	Inches	mm	Inches	mm	Inches	mm
2	3"	4.25	108	4.25	108	56.02	1423	22.99	584	0.55	14	20.31	516	14.57	370
	4"	5.00	127	5.00	127	58.35	1482	25.98	660	0.55	14	20.31	516	14.57	370
3	3"	4.25	108	4.25	108	58.46	1485	27.01	686	0.55	14	24.33	618	16.02	407
	4"	5.00	127	5.00	127	60.79	1544	28.50	724	0.55	14	24.33	618	16.02	407
4	3"	4.25	108	4.25	108	58.78	1493	27.48	698	0.55	14	27.72	704	16.14	410
	4"	5.00	127	5.00	127	61.10	1552	29.02	737	0.55	14	27.72	704	16.14	410
	6"	5.98	152	5.98	152	65.43	1662	34.49	876	0.55	14	29.29	744	16.34	415
6	3"	4.25	108	4.25	108	59.17	1503	28.50	724	0.55	14	29.29	744	16.34	415
	4"	5.00	127	5.00	127	61.50	1562	30.04	763	0.55	14	29.29	744	16.34	415
	6"	5.98	152	5.98	152	65.43	1662	34.49	876	0.55	14	29.29	744	16.34	415
8	4"	5.00	127	5.00	127	70.20	1783	34.02	864	0.55	14	37.87	962	23.27	591
	6"	5.98	152	5.98	152	72.52	1842	39.02	991	0.55	14	37.87	962	21.46	545
	8"	7.24	184	7.24	184	80.63	2048	41.22	1047	0.55	14	37.87	962	25.59	650
10	6"	5.98	152	5.98	152	79.21	2012	42.99	1092	0.55	14	41.89	1064	26.97	685
	8"	7.24	184	7.24	184	83.19	2113	42.01	1067	0.55	14	41.89	1064	26.97	685
	10"	8.50	216	8.50	216	89.25	2267	47.99	1219	0.55	14	47.83	1215	27.95	710

Specifications

Max. Working Pressure: 150 psi (10 bar)

Max. Working Temperature: 167°F (75°C)

Support Legs: Fixed

Lid Closure: Swing Bolts

Multi Bag Housings BH2 - BH10

BH1
100 psi

BH1
150 psi

BH2-
BH10

DBH2-
DBH10

Micron- Rated/
OAB

PPH/PPA

BR

Housing Flow and Volume

Number of Bags	Max Flow		Empty Weight		Housing Volume	
	GPM	L/Min	lbs	kg	Gallons	Liters
2	396	1500	214	97	30.64	116.00
	396	1500	225	102	30.91	117.00
3	594	2250	276	125	49.66	188.00
	594	2250	287	130	49.93	189.00
4	793	3000	355	161	64.46	244.00
	793	3000	373	169	64.72	245.00
	793	3000	454	206	73.70	279.00
6	991	3750	437	198	73.18	277.00
	1189	4500	445	202	73.44	278.00
	1189	4500	454	206	73.70	279.00
8	1387	5250	992	450	129.18	489.00
	1585	6000	992	450	129.71	491.00
	1585	6000	1014	460	130.24	493.00
10	1783	6750	1301	590	174.88	662.00
	1981	7500	1323	600	175.41	664.00
	1981	7500	1576	715	225.60	854.00

How to Build a Valid Model Number for a Multi-Bag Housing, 150 psi:

BOX 1	BOX 2	BOX 3	BOX 4	BOX 5	BOX 6	BOX 7
BH						

Example: NOTE: One option per box

BOX 1	BOX 2	BOX 3	BOX 4	BOX 5	BOX 6	BOX 7
BH	4	2	304S	4F	E	1

= BH42304S4FE1

Filter Model Number Selection

BOX 1	BOX 2	BOX 3	BOX 4	BOX 5
Filter Series	Number of Bags	Bag Size	Material	Connection Size
BH	2 3 4 6 8 10	2	304S = 304 Stainless Steel 316S = 316 Stainless Steel 316L = 316L Stainless Steel	3F = 3" Flange (2, 3, 4, and 6 bags) 4F = 4" Flange (2, 3, 4, 6, and 8 bags) 6F = 6" Flange (4, 6, 8, and 10 bags) 8F = 8" Flange (8 and 10 bags) 10F = 10" Flange (10 bags)
BOX 6	BOX 7			
Seal Material	Pressure Rating			
E = EPDM V = Viton	1 = 150 psi			

Filter and Media are sold separately.
Additional sizes available - call factory for details.