

Features and Benefits

- Improvement in service life for components and system filters
- Increased oil service life
- Increased machine availability
- Simple operation
- Compact design
- Integrated dry running protection
- Optional CS1000 | Contamination Sensor ensures continuous monitoring of oil cleanliness during cleaning

 Part of Schroeder Industries Energy Sustainability Initiative

Description

The HFS-15 Hand Held Portable Filter is used as a portable service unit for filling and flushing hydraulic systems, as well as for cleaning in bypass flow. It can also be fitted with a CS1000 | Contamination Sensor. This allows the solid particle contamination in the oil to be monitored at the same time. The cleanliness class results are displayed according to ISO, SAE or NAS classifications.

Specifications

Flow Rating:	HFS-15-E: 4 gpm (15 L/min) HFS-15-P: 2.6 gpm (9.84 L/min)
Pump Type:	Vane pump
Maximum Operating Pressure:	58 psi (4.0 bar)
Permitted Suction Pressure At Port:	-5.8 to 8.7 psi (-0.4 bar to + 0.6 bar)
Viscosity Range:	HFS-15-E: 42 to 1623 SUS (5 ... cSt) HFS-15-P: 42 to 927 SUS (5 ... cSt)
Fluid Temperature:	14°F to 176°F (-10°C to +80°C)
Ambient Temperature:	14°F to 104°F (-10°C to +40°C)
Seal Material:	FKM (FPM, Viton [®])
Weight:	HFS-15-E: 30.9 lbs. (14 kg) HFS-15-P: 36.4 lbs. (16.5 kg)
Hoses w/ crimped wands (standard):	Suction hose length: 8.2' (2.5m) Return hose length: 8.2' (2.5m) Hose material: PVC Wand material: Zinc-plated steel

Hand Held Portable Filter

HFS-15

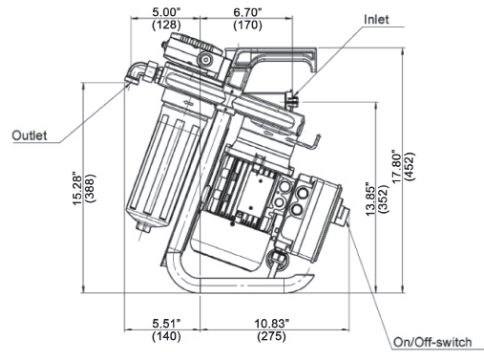
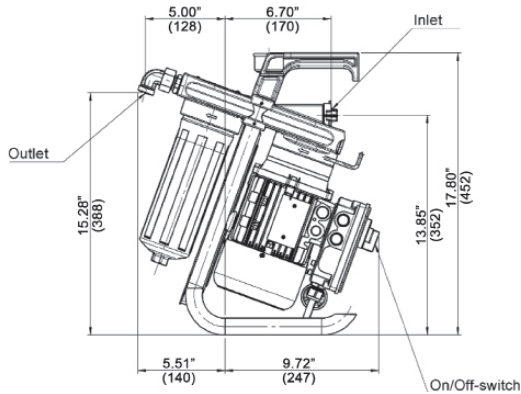

Economy

Premium

Metric dimensions in ().

How to Build a Valid Model Number for a Schroeder HFS-15:

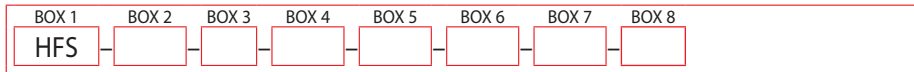

Example: NOTE: One option per box

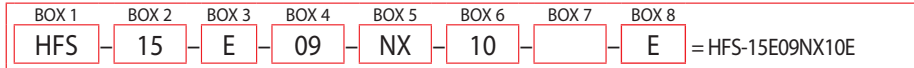

BOX 1	BOX 2	BOX 3	BOX 4	BOX 5
Model	Size	Type	Element Length	Filter Rating
HFS	15 = 4 gpm (15 L/min) (for type "E" only) 10 = 2.6 gpm (10 L/min) (for type "P" only)	E = Economy P = Premium (w/ Condition Monitoring)	09	NX = Particulate Removal Element AM = Water Removal

BOX 6
Element Media
03 = 3 µm Excellement® Z-Media® (synthetic)
05 = 5 µm Excellement® Z-Media® (synthetic)
10 = 10 µm Excellement® Z-Media® (synthetic)
25 = 25 µm Excellement® Z-Media® (synthetic)
GW = Water Removal

BOX 7
Power Supply
Omit = 120 V, 60 Hz, 1 Ph (0.25 kW)
D = Compressed Air (only Type E)
M = 230 VAC 50 hertz single phase
T = 12V DC (0.2kW) (only for TYPE E and P)
U = 24V DC (0.2kW) (only for TYPE E and P)

BOX 8
Clogging Indicator
E = Back-pressure indicator

Hoses with threaded connection (depressurized suction up to max. 350 mm²/s)

Description	Part no.	Suction Hose/ Pressure Hose	Thread	Material Suction/ Pressure Hose
MFU-15-SKD5F	4270516	2.5 m / 5 m	M30x2 / M26x1.5	1SN / 2TE

Accessories For Hoses With Threaded Connection

Description	Part No.	Function
MFU-15-SKDK-LF	4270559	Wand ¹ (length of 1.30 m)
MFU-15-SKDK-SF	4270560	Suction filter ¹
MFU-15-SKDK-ZWF	4270518	Counter
MFU-15-SKDK-ZPF	4270561	Pump Nozzle ²
MFU-15-SKDK-ZPWF	4270519	Pump Nozzle + Counter ²

¹max. viscosity 200 mm²/s

²max. operation duration of the unit with closed pump nozzle of 5 - 10 min.

Economy & Premium

Model Number Selection

- CS 1000
- CS 1939
- CSI-C-11
- HY-TRAX®
- RBSA
- CSM
- FCU
- MCS
- AS
- SMU
- CTU
- EPK
- Trouble Check Plus
- HMG2500
- HMG4000
- ET-100-6
- HTB
- RFSA
- HFS-BC
- HFS-15**
- MFD-BC
- MFS, MFD
- HY-TRAX® Retrofit System
- MFD-MV
- MFS-HV
- AMS, AMD
- FS
- AMFS
- KLS, KLD
- KLCO
- MCO
- AKS, AKD
- LSN, LSA, LSW
- X Series
- OLF Compact
- OLF
- OLF-P
- NxTM
- VEU-F
- VMU
- IXU
- Triton-A
- Triton-E
- NAV
- SVD01
- OXS
- Appendix

Accessories

Notes