

Base-Ported Pressure Filter

KC50



Features and Benefits

- Base-ported pressure filter
- Patented dirt-tolerant cap design
- Can be installed in vertical or horizontal position
- Meets HF4 automotive standard
- Element changeout from top minimizes oil spillage
- Offered in pipe, SAE straight thread, flanged and ISO 228 porting
- No-Element indicator option available
- Available with non-bypass option with high collapse element
- Integral inlet and outlet female test points option available
- Offered in conventional subplate porting
- Double and triple stacking of K-size elements can be replaced by single KK or 27K-size elements
- Available with quality-protected GeoSeal® Elements (GKC50)

100/150 gpm NF30
380/570 L/min NFS30
5000 psi YF30
345 bar CFX30

PLD

CF40

DF40

PF40

RFS50

RF60

CF60

CTF60

VF60

LW60

KF30

KF50

TF50

Model No. of filter in photograph is KC501KZ10PD.

Flow Rating:	Up to 100 gpm (380 L/min) for 150 SUS (32 cSt) fluids With 2" porting only, up to 150 gpm (570 L/min) for 150 SUS (32 cSt) fluids
Max. Operating Pressure:	5000 psi (345 bar)
Min. Yield Pressure:	15,000 psi (1035 bar), per NFPA T2.6.1
Rated Fatigue Pressure:	3500 psi (240 bar), per NFPA T2.6.1-2005
Temp. Range:	-20°F to 225°F (-29°C to 107°C)
Bypass Setting:	Cracking: 40 psi (2.8 bar) Optional Cracking: 50 psi (3.5 bar) Full Flow: 61 psi (4.2 bar) Non-bypassing model has a blocked bypass.
Porting Base & Cap:	Ductile Iron
Element Case:	Steel
Weight of KF30-1K:	66.8 lbs. (30.3 kg)
Weight of KF30-2K:	87.8 lbs. (39.8 kg)
Weight of KF30-3K:	109.6 lbs. (49.7 kg)
Element Change Clearance:	8.50" (215 mm) for 1K; 17.50" (445 mm) for KK; 26.5" (673 mm) for 27K

Filter Housing Specifications

KC50

MKF50

MKC50

KC65

HS60

MHS60

KFH50

LC60

LC35

LC50

NOF30-05

Type Fluid	Appropriate Schroeder Media
Petroleum Based Fluids	All E-Media (cellulose) and Z-Media® and ASP® Media (synthetic)
High Water Content	All Z-Media® and ASP® Media (synthetic)
Invert Emulsions	10 and 25 µ Z-Media® (synthetic), 10 µ ASP® Media (synthetic)
Water Glycols	3, 5, 10 and 25 µ Z-Media® (synthetic), and all ASP® Media
Phosphate Esters	All Z-Media® and ASP® Media (synthetic) with H (EPR) seal designation and 3 and 10 µ E media (cellulose) with H (EPR) seal designation
Skydrol®	3, 5, 10 and 25 µ Z-Media® (synthetic), and all ASP® Media (synthetic) with H.5 seal designation (EPR seals and stainless steel wire mesh in element, and light oil coating on housing exterior)

Fluid Compatibility

NOF-50-760

FOF60-03

NMF30

RMF60

14-CRZX10

20-CRZX10

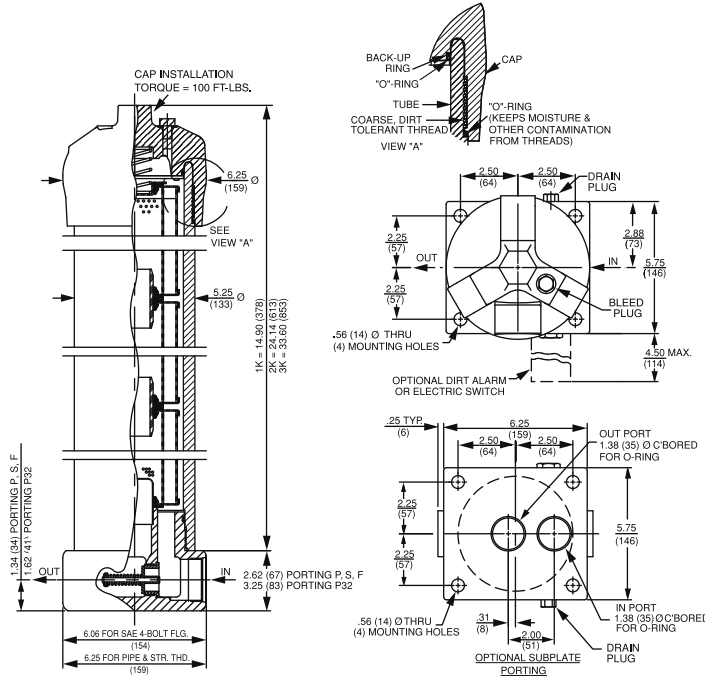

Metric dimensions in ().
 Dimensions shown are inches (millimeters) for general information and overall envelope size only.
 For complete dimensions please contact Schroeder Industries to request a certified print.

Element Performance Information & Dirt Holding Capacity

Element	Filtration Ratio Per ISO 4572/NFPA T3.10.8.8 Using automated particle counter (APC) calibrated per ISO 4402			Filtration Ratio per ISO 16889 Using APC calibrated per ISO 11171	
	$\beta_x \geq 75$	$\beta_x \geq 100$	$\beta_x \geq 200$	$\beta_x(c) \geq 200$	$\beta_x(c) \geq 1000$
KZ1/KKZ1/27KZ1	<1.0	<1.0	<1.0	<4.0	4.2
KZ3/KKZ3/27KZ3	<1.0	<1.0	<2.0	<4.0	4.8
KZ5/KKZ5/27KZ5	2.5	3.0	4.0	4.8	6.3
KZ10/KKZ10/27KZ10	7.4	8.2	10.0	8.0	10.0
KZ25/KKZ25/27KZ25	18.0	20.0	22.5	19.0	24.0
KZW1	N/A	N/A	N/A	<4.0	<4.0
KZW3/KKZW3	N/A	N/A	N/A	4.0	4.8
KZW5/KKZW5	N/A	N/A	N/A	5.1	6.4
KZW10/KKZW10	N/A	N/A	N/A	6.9	8.6
KZW25/KKZW25	N/A	N/A	N/A	15.4	18.5
KZX3/KKZX3/27KZX3	<1.0	<1.0	<2.0	4.7	5.8
KZX10/KKZX10/27KZX10	7.4	8.2	10.0	8.0	9.8

Element	DHC (gm)	Element	DHC (gm)	Element	DHC (gm)	Element	DHC (gm)	Element	DHC (gm)
KZ1	112	KKZ1	224	27KZ1	336	KZW1	61		
KZ3	115	KKZ3	230	27KZ3	345	KZW3	64	KKZW3	128
KZ5	119	KKZ5	238	27KZ5	357	KZW5	63	KKZW5	126
KZ10	108	KKZ10	216	27KZ10	324	KZW10	57	KKZW10	114
KZ25	93	KKZ25	186	27KZ25	279	KZW25	79	KKZW25	158
KZX3	40*	KKZX3	80	27KZX3	120				
KZX10	49*	KKZX10	98	27KZX10	147				

* Based on 100 psi terminal pressure

Element Collapse Rating: 150 psid (10 bar) for standard elements
 3000 psid (210 bar) for high collapse (ZX) versions

Flow Direction: Outside In

Element Nominal Dimensions: K: 3.9" (99 mm) O.D. x 9.0" (230 mm) long
 KK: 3.9" (99 mm) O.D. x 18.0" (460 mm) long
 27K: 3.9" (99 mm) O.D. x 27.0" (690 mm) long

Base-Ported Pressure Filter

KC50

$\Delta P_{\text{housing}}$

KC50 $\Delta P_{\text{housing}}$ for fluids with sp gr (specific gravity) = 0.86:

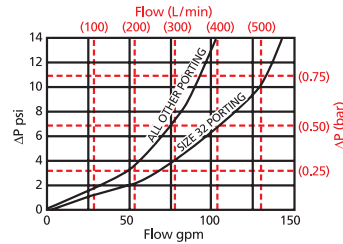

$\Delta P_{\text{element}}$

KZ/KGZ

Element Pressure Drop versus Flow Rate at 32 cSt (150 SUS)

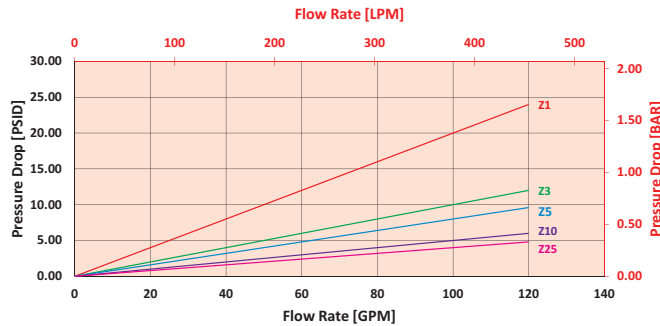

2KZ/KKGZ

Element Pressure Drop versus Flow Rate at 32 cSt (150 SUS)

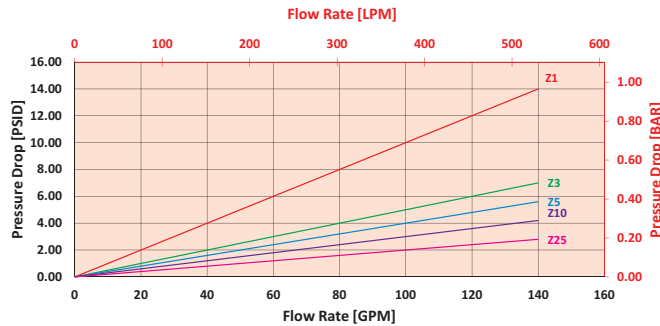

$$\Delta P_{\text{filter}} = \Delta P_{\text{housing}} + (\Delta P_{\text{element}} * V_f)$$

Exercise:

Determine ΔP_{filter} at 50 gpm (189.5 L/min) for KC501KZ10SD5 using 160 SUS (34 cSt) fluid.

Use the housing pressure curve to determine $\Delta P_{\text{housing}}$ at 50 gpm. In this case, $\Delta P_{\text{housing}}$ is 3 psi (.21 bar) on the graph for the KC50 housing.

Use the element pressure curve to determine $\Delta P_{\text{element}}$ at 50 gpm. In this case, $\Delta P_{\text{element}}$ is 2.5 psi (.17 bar) according to the graph for the KZ10 element.

Because the viscosity in this sample is 160 SUS (34 cSt), we determine the **Viscosity Factor (V_f)** by dividing the **Operating Fluid Viscosity** with the **Standard Viscosity** of 150 SUS (32 cSt). To best determine your Operating Fluid Viscosity, please reference the chart in Appendix D.

Finally, the overall filter pressure differential, ΔP_{filter} , is calculated by adding $\Delta P_{\text{housing}}$ with the true element pressure differential, $(\Delta P_{\text{element}} * V_f)$. The $\Delta P_{\text{element}}$ from the graph has to be multiplied by the viscosity factor to get the true pressure differential across the element.

Solution:

$$\Delta P_{\text{housing}} = 3 \text{ psi } [.21 \text{ bar}] \quad | \quad \Delta P_{\text{element}} = 2.5 \text{ psi } [.17 \text{ bar}]$$

$$V_f = 160 \text{ SUS (34 cSt)} / 150 \text{ SUS (32 cSt)} = 1.1$$

$$\Delta P_{\text{filter}} = 3 \text{ psi} + (2.5 \text{ psi} * 1.1) = 5.8 \text{ psi}$$

OR

$$\Delta P_{\text{filter}} = .21 \text{ bar} + (.17 \text{ bar} * 1.1) = .40 \text{ bar}$$

Pressure Drop Information Based on Flow Rate and Viscosity

Note:

If your element is not graphed, use the following equation:

$\Delta P_{\text{element}} = \text{Flow Rate} \times \Delta P_f$ Plug this variable into the overall pressure drop equation.

Ele.	ΔP	Ele.	ΔP	Ele.	ΔP
K3	0.25	2K3/ KK3	0.12	3KZ1/ 27KZ1	0.05
K10	0.09	2K10/ KK10	0.05	3KZ3/ 27KZ3	0.03
K25	0.02	2K25/ KK25	0.01	3KZ5/ 27KZ5	0.02
KAS3	0.10	2KAS3/ KKAS3	0.05	3KZ10/ 27KZ10	0.02
KAS5	0.08	2KAS5/ KKAS5	0.04	3KZ25/ 27KZ25	0.01
KAS10	0.05	2KAS10/ KKAS10	0.03	3K3	0.08
KZX10	0.22	2KZX10/ KKZX10	0.11	3K10	0.03
KZW1	0.43	2KZW1	-	3K25	0.01
KZW3	0.32	2KZW3/ KKZW3	0.16	3KAS3/ 27KAS3	0.03
KZW5	0.28	2KZW5/ KKZW5	0.14	3KAS5/ 27KAS5	0.02
KZW10	0.23	2KZW10/ KKZW10	0.12	3KAS10/ 27KAS10	0.02
KZW25	0.14	2KZW25/ KKZW25	0.07	3KAS25/ 27KAS25	0.07

Filter Model Number Selection

How to Build a Valid Model Number for a Schroeder KC50:

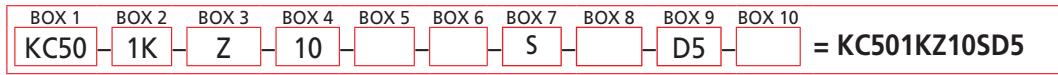
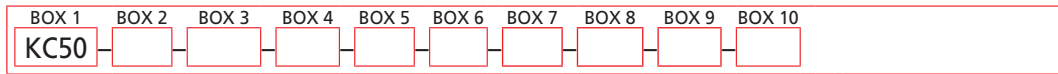

BOX 1	BOX 2	BOX 3
Filter Series	Number & Size of Elements	Media Type
KC50	1 K, KK, 27K	Omit = E Media (Cellulose) (KC50 only)
KCN50 (Non-bypassing: requires ZX high collapse elements)	2 K	AS = Anti-Stat Media (synthetic)
	3 K	Z = Excellence® Z-Media® (synthetic)
	GeoSeal® Options	ZX = Excellence® Z-Media® (High Collapse centertube) (KCN50 Only)
	1 KG, KKG, 27KG	ZW = Aqua-Excellence ZW Media (KC50 Only)
	2 KG	W = W Media (water removal)
	3 KG	M = Media (reusable metal mesh) (KC50 & KCN50 Only)
GKC50 (GeoSeal®)		
WKC50 (Water)		

NOTES:

Box 2. Number of elements must equal 1 when using KK or 27K elements. Replacement element part numbers are identical to contents of Boxes 2, 3, 4 and 5. Double and triple stacking of K-size elements can be replaced by single KK and 27K elements, respectively. ZW media not available in 27K length. For standard elements, a plastic connector SAP P/N: 7630900 (LF-1997) is used to connect two or three K elements. For high collapse, a steel connector is required SAP P/N: 7608360 (LF-3255C).

Box 5. H.5 seal designation includes the following: EPR seals, stainless steel wire mesh on elements, and light oil coating on housing exterior. Viton® is a registered trademark of DuPont Dow Elastomers. Skydrol® is a registered trademark of Solutia Inc.

Box 7. For option F, bolt depth .75" (19 mm). For option O, O-rings included; hardware not included.

Box 8. X and 50 options are not available with KCN50.

Box 9. Standard indicator setting for non-bypassing model is 50 psi unless otherwise specified.

Box 10. Option N, are not available with KCN50/ GKC50. N option should be used in conjunction with dirt alarm.

BOX 4	BOX 5	BOX 6	BOX 7
Micron Rating	Seal Material	Magnet Option	Porting
1 = 1 Micron (Z, ZW, ZX media)	Omit = Buna N	Omit = None	P = 1 1/2" NPTF
3 = 3 Micron (AS,E, Z, ZW, ZX media)	V = Viton®	M = Magnet inserts (not available w/ indicator in cap)	P32 = 2" NPTF
5 = 5 Micron (AS, Z, ZW, ZX media)	H = EPR		S = SAE-24
10 = 10 Micron (AS,E,M, Z, ZW, ZX media)	H.5 = Skydrol® compatibility		F = 1 1/2" SAE 4-bolt flange Code 62
25 = 25 Micron (E,M, Z, ZW, ZX media)			O = Subplate
60 = 60 Micron (M media)			B24 = ISO 228 G-1 1/2"
150 = 150 Micron (M media)			
260 = 260 Micron (M media)			

BOX 8	BOX 9	BOX 10
Options	Dirt Alarm® Options	Additional Options
Omit = None	None	Omit = None
X = Blocked bypass	Omit = None	N = No-Element Indicator (not available w/ KCN50 or GKC50 housings w/ indicator in cap)
50 = 50 psi bypass setting	D = Pointer	G509 = Dirt Alarm and drain opposite standard
L = Two 1/2" NPTF inlet & outlet female test ports	D5 = Visual pop-up	G588 = Electric Switch and drain opposite standard
U = Series 1215 7/16 UNF Schroeder Check Test Point installed in cap (upstream)	D5C = D5 in cap	
UU = Series 1215 7/16 UNF Schroeder Check Test Point installed in block (upstream and downstream)	D9 = All stainless D5	
	D8 = Visual w/ thermal lockout	
	D8C = D8 in cap	
	MS5 = Electrical w/ 12 in. 18 gauge 4-conductor cable	
	MS5LC = Low current MS5	
	MS10 = Electrical w/ DIN connector (male end only)	
	MS10LC = Low current MS10	
	MS11 = Electrical w/ 12 ft. 4-conductor wire	
	MS12 = Electrical w/ 5 pin Brad Harrison connector (male end only)	
	MS12LC = Low current MS12	
	MS16 = Electrical w/ weather-packed sealed connector	
	MS16LC = Low current MS16	
	MS17LC = Electrical w/ 4 pin Brad Harrison male connector	
	MS5T = MS5 (see above) w/ thermal lockout	
	MS5LCT = Low current MS5T	
	MS10T = MS10 (see above) w/ thermal lockout	
	MS10LCT = Low current MS10T	
	MS12T = MS12 (see above) w/ thermal lockout	
	MS12LCT = Low current MS12T	
	MS16T = MS16 (see above) w/ thermal lockout	
	MS16LCT = Low current MS16T	
	MS17LCT = Low current MS17T	
	MS = Cam operated switch w/ 1/2" conduit female connection	
	MS13DC = Supplied w/ threaded connector & light	
	MS14DC = Supplied w/ 5 pin Brad Harrison connector & light (male end)	
	MS13DCT = MS13 (see above), direct current, w/ thermal lockout	
	MS13DCLCT = Low current MS13DCT	
	MS14DCT = MS14 (see above), direct current, w/ thermal lockout	
	MS14DCLCT = Low current MS14DCT	