



## SYSTEM AVAILABILITY

# Fluid Conditioning and Monitoring of Plastic Injection Molding Machine

### Technical Application Bulletin

#### PROJECT BACKGROUND

##### DISCOVER

- Top 100, tier 1 supplier of injection molded interior parts to automotive industry
- 40 injection molding machines (IMMs) in facility
- Experiencing high annual machine down-time and consequential costs
- Plant maintenance manager explained that a large portion of down-time was caused by hydraulic system failures



##### DIAGNOSE

- Approximately 50% of machine down-time was related to hydraulic system failures, or \$20,000 per IMM
  - 2x servo proportional valve replacements per year (\$4,000 ea.)
  - \$1,000 annual fluid replacement cost
  - \$5,000 other contamination-related costs (labor, components, etc.)
- Hydraulic fluid of targeted IMM contaminated to an ISO 4406:2017 cleanliness of 21/17/11, or 3x higher than required

#### INDUSTRIES



#### DESIGN

##### Course of action:

1. After explaining the consequential effects of poor fluid contamination and diagnosing the situation, it was clear to the plant manager that corrective action needed taken.
2. SI presented an OLF-Compact offline filtration solution--with integrated contamination monitoring--and hypothesized that it could improve the cleanliness to the required ISO 4406:2017 cleanliness of at least 17/15/12. By improving the cleanliness, it was estimated that the service life of the servo proportional valve would be extended by factor of 2, would eliminate the need for annual fluid replacement, and would reduce hydraulic system-based downtime costs by approximately \$10,000 for the targeted IMM.

##### Solution design:

1. **Panel-mounted**
  - Minimized footprint
2. **OLF-5/15-S-370-K-N5DM002-E/-12-7.5**
  - Compact pump/motor/filter assembly
  - N5DM002, high-capacity/efficiency filter element technology
3. **CS1220-A-0-0-0-1/-K**
  - Particle contamination sensor capable of measuring per ISO 4406:1999 and SAE 4059 (D) standards
4. **CSI-C-11-0-0-0/-000**
  - Sensor data logger and transmitter (WLAN/LAN)
  - Manage data via FluMoS Mobile
5. **RFSA, DIN24557/T2**
  - Reservoir breather adapter for ease-of-integration
  - DIN24557/T2 bolt pattern

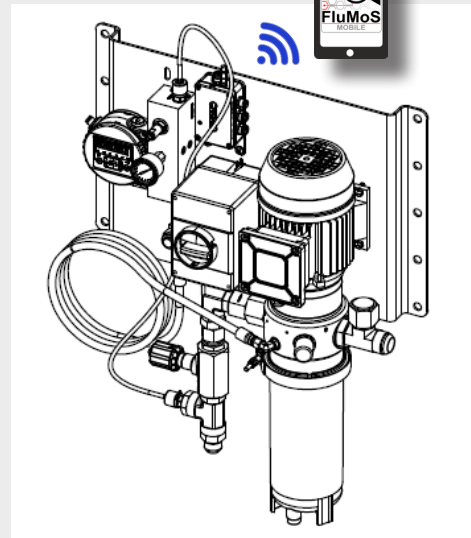

## DELIVER

### Implementation and evaluation:

- The SI solution provided the customer with exceptional fluid filtration within the first two months of installation by improving the cleanliness to 17/15/12.
- After the first year of installation, the fluid cleanliness improved to less than 15/13/11, and extended the service life of the servo proportional valves by a minimum factor of 2; the customer replaced no servo proportional valves since the installation of the SI solution.
- Simultaneously, the customer did not need to replace the hydraulic fluid, nor incur other contamination-related hydraulic system failure costs.

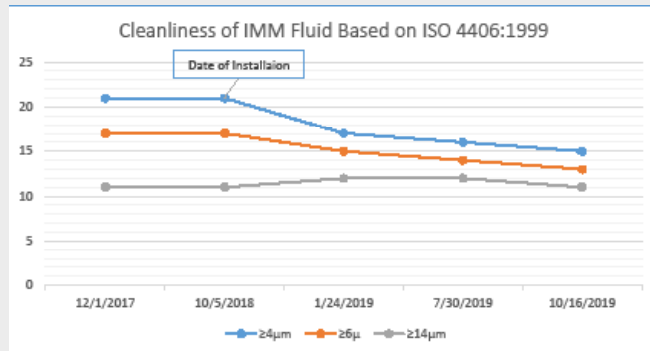
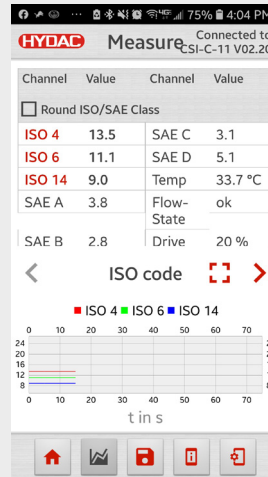

Injection Molding Machine	Without SI Solution	With SI Solution	Savings
Hydraulic system failures	\$20,000	\$6,000	+\$14,000
Annual fluid replacement	\$1,000	\$0	+\$1,000
Servo prop. valve repair	\$8,000	\$0	+\$8,000
Other related cost	\$5,000	\$0	+\$5,000
SI solution cost	\$0	\$8,500	-\$8,500
Filter Element Cost	\$0	\$1,175	-\$1,175

## CUSTOMER BENEFITS

- Increased availability and up-time
- Increased productivity and performance
- Compliance with safety regulations and machine directives
- No downtime required to replace offline filter system elements

## FURTHER APPLICATION AREAS

- Paper Industry
- Steel Industry
- Automotive Industry
- Chemical Industry

## ROI

### ROI After 1 year



145%

### Estimated ROI, Year 2



192%

### BEP on Investment



5 Months

### Underlying assumptions:

Servo prop valves requiring repair/replacement in year two: 1

Filter elements replaced in year two: 2

## PRODUCT SPECS

### OLF-5/15 | Compact Offline Filter System

Flow Rating: 4.9 gpm

Max. Viscosity: 3,600 SUS

Max. Operating Pressure: 109 psi (7.5 bar)

Fluid Temperature:

32°F to 175°F

Seals: Buna N

Dirt Holding Capacity:

200g ISO MTD (N5DM particulate)

185g ISO MTD (N5AM water)

Weight: 24.3 lbs. (11.0 kg)

\*Contact Filter Systems for remaining product specifications