

Oil Sight Glasses



Schroeder Oil Sight Glasses provide maintenance and lubrication management professionals a complete and immediate visual oil analysis. Constructed of durable cast acrylic, they withstand most petroleum products to remain crystal clear. Although easy detection and discharge of water contamination are leading benefits, operators can also visually monitor the oil for discoloration or debris. The drain valve is made from brass with a vulcanized rubber seal. Both materials have excellent resistance to hydrocarbon and petroleum-based products, hydraulic fluids, most silicone fluids, and fuels. A detailed chemical resistance chart is available upon request.

Our Oil Sight Glass product line includes models for vertical and horizontal mounting, high temperature applications, large volume bowls, level indication and the all encompassing Oil Sight Glass and Level Monitor. The revolutionary 3-D Oil Sight Glass can replace the problematic, old-fashioned sight plug on your oil reservoir to provide greater visibility.

Benefits

- Withstand most petroleum products to remain crystal clear
- Continuously monitor oil level and condition
- Extremely low maintenance
- Low purchase and installation costs
- Save expensive equipment through early detection and action

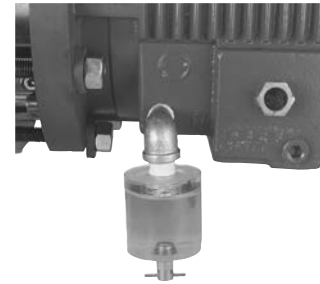

For many systems the 1 oz. Oil Sight Glass is adequate. The 3 oz. Oil Sight Glass provides additional volume and should be used when the condensation or water spillover is excessive. Schroeder also offers 16 oz. and 32 oz. Oil Sight Glasses for special applications that require the ability to accumulate substantial volumes of water due to large oil reservoirs, high condensation problems or excessive water spillover. Even larger sizes and unique configurations are available for special applications.

	1 oz. Oil Sight Glass	3 oz. Oil Sight Glass
Outside Diameter:	1.75 (44)	2.50 (64)
Length:	2.38 (60)	2.38 (60)
Maximum psi (bar):	225 (16)	200 (14)
Operating Temperature:	-40°F to 165°F -40°C to 74°C	-40°F to 165°F -40°C to 74°C
Specifications:	Commercial grade acrylic Brass drain valve ¼", ⅜" or ½" NPT brass nipples Vertical and horizontal styles Available in 16 oz and 32 oz sizes Stainless steel hardware available	



VERTICAL

Metric dimensions in ().

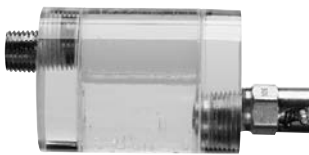

HORIZONTAL

Horizontal Oil Sight Glass

The *Horizontal* Oil Sight Glass is designed to be installed on equipment that has restricted vertical clearance. The design has the mounting nipple and drain valve eccentrically machined and oriented 180° apart. This provides the same ability to discharge any accumulated water.

How to Order

Part No.	Description	Part No.	Description
OSG1X250	Vertical 1 oz ¼" NPT	OSG1X250HZ	Horizontal 1 oz ¼" NPT
OSG1X375	Vertical 1 oz ⅜" NPT	OSG1X375HZ	Horizontal 1 oz ⅜" NPT
OSG1X500	Vertical 1 oz ½" NPT	OSG1X500HZ	Horizontal 1 oz ½" NPT
OSG3X250	Vertical 3 oz ¼" NPT	OSG3X250HZ	Horizontal 3 oz ¼" NPT
OSG3X375	Vertical 3 oz ⅜" NPT	OSG3X375HZ	Horizontal 3 oz ⅜" NPT
OSG3X500	Vertical 3 oz ½" NPT	OSG3X500HZ	Horizontal 3 oz ½" NPT
OSG16X500	Vertical 16 oz ½" NPT		
OSG32X500	Vertical 32 oz ½" NPT		

Oil Sight Glasses

Air Breathers

When oil operating temperatures or radiant heat from adjacent equipment are continually in excess of 165°F, you should consider utilizing the Schroeder High Temperature Oil Sight Glass.

	1 oz. Oil Sight Glass	3 oz. Oil Sight Glass
Outside Diameter:	2.75 (70)	3.50 (89)
Length:	2.50 (64)	2.50 (64)
Maximum psi (bar):	225 (16)	225 (16)
Operating Temperature:	450°F 232°C	450°F 232°C
Specifications:	Heavy-walled Pyrex glass Teflon™ end plates Stainless steel nuts and bolts Viton® O-rings Brass drain valve ¼", ⅜" or ½" NPT brass nipples Vertical style only Stainless steel hardware available	

Metric dimensions in ().

Part No.	Description
OSG1X250HT	High Temp 1 oz ¼" NPT
OSG1X375HT	High Temp 1 oz ⅜" NPT
OSG1X500HT	High Temp 1 oz ½" NPT
OSG3X250HT	High Temp 3 oz ¼" NPT
OSG3X375HT	High Temp 3 oz ⅜" NPT
OSG3X500HT	High Temp 3 oz ½" NPT

Any oil sight glass can be equipped with a rare earth magnet that attracts and holds microscopic ferrous particles in your oil. Further analysis of these particles can help determine what component is failing for replacement. The magnet drain valve is easily interchanged with the standard drain valve on any OSG product.

High Temperature Oil Sight Glass

Suction Separators and Strainers



How to Order

Magnet Option



Oil Sight Glasses

Oil Sight Glass & Level Monitor



When seeing and maintaining the level of oil in your reservoir is critical, the Oil Sight Glass and Level Monitor (OSGL) provides all the benefits of the OSG plus the ability to constantly monitor the level of the reservoir oil. The dual port model has a second $\frac{3}{8}$ " NPT thread at 180° to allow the installation of a drain valve or access to the oil reservoir utilizing a pilot tube and a pitot sample adapter. This all-in-one product provides continuous monitoring of the clarity, color, sediment, water contamination and level of the oil.

Outside Diameter:	1.75 (44)
Length:	3" (76), 6" (152), 9" (229), 12" (305), 15" (381), 18" (457), 24" (610), or custom available
Maximum psi (bar):	225 (16)
Operating Temperature:	-40°F to 165°F -40°C to 74°C
Specifications:	Commercial grade acrylic Brass drain valve $\frac{3}{8}$ " NPT brass nipples Available in dual port version with a second $\frac{3}{8}$ " NPT port Stainless steel hardware available

Metric dimensions in ().

How to Order

Part No.	Description
OSGL3	OSG and Level Monitor 3" (76)
OSGL6	OSG and Level Monitor 6" (152)
OSGL9	OSG and Level Monitor 9" (229)
OSGL12	OSG and Level Monitor 12" (305)
OSGL3DP	OSG and Dual Port Level Monitor 3" (76)
OSGL6DP	OSG and Dual Port Level Monitor 6" (152)
OSGL9DP	OSG and Dual Port Level Monitor 9" (229)
OSGL12DP	OSG and Dual Port Level Monitor 12" (305)
OSGL15	OSG and Level Monitor 15" (381)
OSGL18	OSG and Level Monitor 18" (457)
OSGL24	OSG and Level Monitor 24" (610)
OSGL15DP	OSG and Dual Port Level Monitor 15" (381)
OSGL18DP	OSG and Dual Port Level Monitor 18" (457)
OSGL224DP	OSG and Dual Port Level Monitor 24" (610)

Oil Sight Glasses

Air Breathers

Suction Separators and Strainers

When seeing and maintaining the level of oil in your reservoir is critical, the Sight Level Gauge (SLG) provides constantly monitoring of the oil level in the reservoir.

SLG Fluid Level Indicator

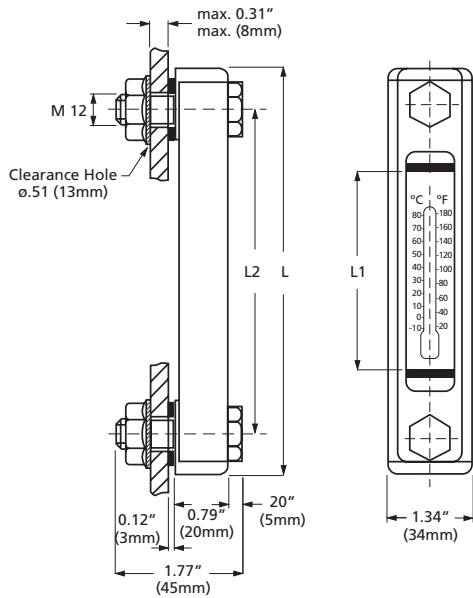

Oil Sight Glasses

Model Code	Size	Dimensions		
		L	L1	L2
SLG-3	76	4.25"	1.46"	2.99"
SLG-5	127	6.26"	2.99"	5.00"
SLG-10	254	11.26"	7.99"	10.00"

Oil Sight Glasses

3-D Oil Sight Glass



The 3-D Oil Sight Glass is machined from one solid piece of impact resistant, high strength, stain-resistant cast acrylic. It has excellent resistance to hydrocarbon and petroleum-based products, hydraulic fluids, most silicone fluids, and fuels. Replaces problematic, old-fashioned oil level sight plugs. Fits virtually every oil reservoir. Revolutionary easy view design is visible from virtually any angle, minimizing false positives.

NPT:	½", ¾", 1", 1¼", 1½", 2"
Outside Diameter:	⅞", 1⅛", 1⅜", 1¾", 2", 2½"
Length:	1", 1½" from last thread. Metric and custom sizes available.
Maximum psi (bar):	300 (21)
Operating Temperature:	200°F (93°C) at 66 psi (5 bar) 230°F (110°C) at atmospheric pressure

Metric dimensions in ().

How to Order

Part No.	Description	Part No.	Description
3DBM10X1.0	Metric 10 x 1.0	3DB0250	¼" NPT
3DBM10X1.5	Metric 10 x 1.5	3DB0375	⅜" NPT
3DBM12X1.5	Metric 12 x 1.5	3DB0500	½" NPT
3DBM16X1.5	Metric 16 x 1.5	3DB0750	¾" NPT
3DBM20X1.5	Metric 20 x 1.5	3DB1000	1" NPT
3DBM22X1.5	Metric 22 x 1.5	3DB1250	1¼" NPT
3DBM24X1.5	Metric 24 x 1.5	3DB1500	1½" NPT
3DBM26X1.5	Metric 26 x 1.5	3DB2000	2" NPT
3DBM27X1.5	Metric 27 x 1.5		
3DBM30X2.0	Metric 30 x 2.0		
3DBM33X1.5	Metric 33 x 1.5		



BEFORE

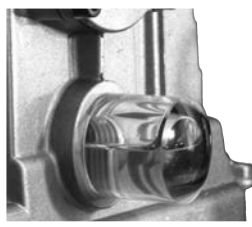

AFTER

