

Tank-Mounted Suction Filter

ST



Features and Benefits

- Tank-mounted suction filter for hydrostatic suction service
- Optional check valve prevents reservoir siphoning
- Easy Element changeout
- Inlet filter protects pump, reduces start-up failures

20 gpm
75 L/min

ST

SKF3

TF-SKB

KF3-SKB

BFT-SKB

Model No. of filter in photograph is ST1K10SY.

Flow Rating:	Up to 20 gpm (75 L/min) for 150 SUS (32 cSt) fluids
Max. Operating Pressure:	Suction Filter
Min. Yield Pressure:	Not Applicable
Rated Fatigue Pressure:	Not Applicable
Temp. Range:	-20°F to 225°F (-29°C to 107°C)
Bypass Setting:	Non-bypassing
Porting Head:	Die Cast Aluminum
Cap:	Steel
Element Case:	Steel
Weight of ST-1K:	11.1 lbs. (5.0 kg)
Weight of ST-2K:	14.7 lbs. (6.7 kg)
Element Change Clearance:	7.25" (185 mm) for 1K; 17.50" (445 mm) for KK

Filter Housing Specifications

Type Fluid	Appropriate Schroeder Media
Petroleum Based Fluids	All E media (cellulose) and Z-Media [®] (synthetic)
High Water Content	10 μ Z-Media [®] (synthetic)
Invert Emulsions	10 μ Z-Media [®] (synthetic)
Water Glycols	10 μ Z-Media [®] (synthetic)
Phosphate Esters	10 μ Z-Media [®] (synthetic) with H (EPR) seal designation and 10 μ E media (cellulose) with H (EPR) seal designation
Skydrol [®]	10 μ Z-Media (synthetic) with H.5 seal designation (EPR seals and stainless steel wire mesh in element, and light oil coating on housing exterior)

Fluid Compatibility

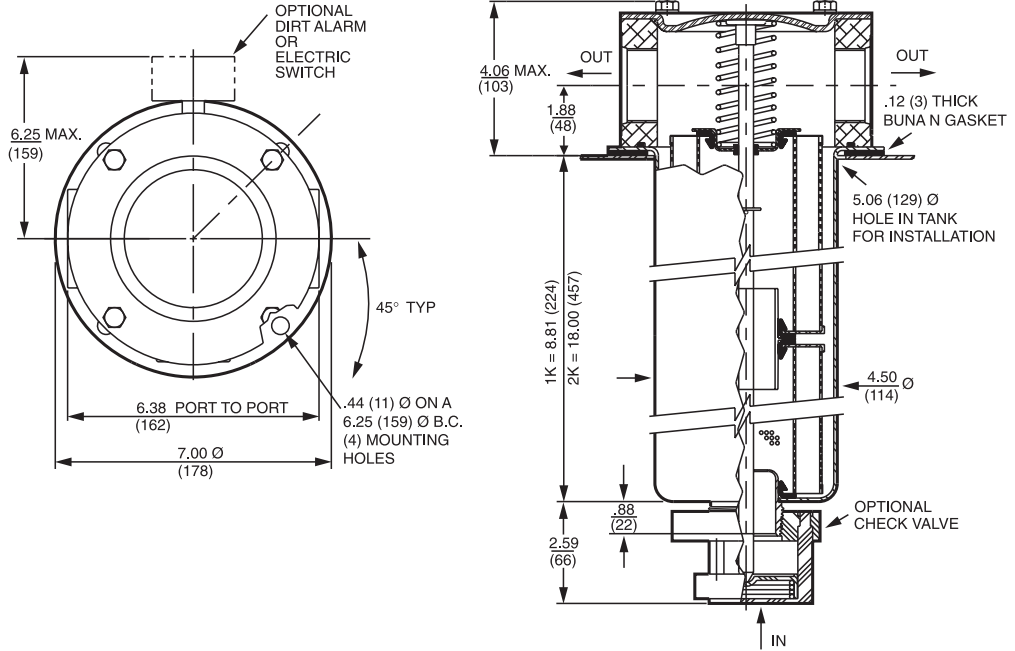

Metric dimensions in ().

Element Performance Information & Dirt Holding Capacity

Element	Filtration Ratio Per ISO 4572/NFPA T3.10.8.8 Using automated particle counter (APC) calibrated per ISO 4402			Filtration Ratio per ISO 16889 Using APC calibrated per ISO 11171	
	$\beta_x \geq 75$	$\beta_x \geq 100$	$\beta_x \geq 200$	$\beta_x(c) \geq 200$	$\beta_x(c) \geq 1000$
KTZ10	7.4	8.0	10.0	8.0	10.0

Element	DHC (gm)
KTZ10	56

Element Collapse Rating: 150 psid (10 bar)

Flow Direction: Inside Out

Element Nominal Dimensions: 3.9" (99 mm) O.D. x 9.0" (230 mm) long

$\Delta P_{\text{housing}}$

ST $\Delta P_{\text{housing}}$ for fluids with sp gr (specific gravity) = 0.86:

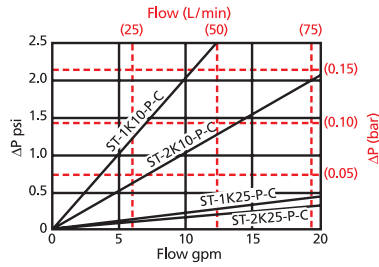

$\Delta P_{\text{element}}$

KTZ

Element Pressure Drop versus Flow Rate at 32 cSt (150 SUS)

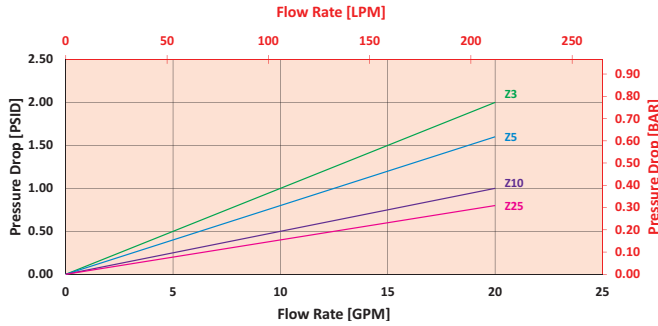

2KTZ

Element Pressure Drop versus Flow Rate at 32 cSt (150 SUS)

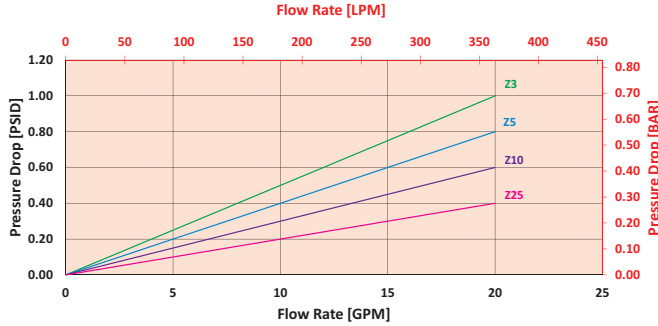

$$\Delta P_{\text{filter}} = \Delta P_{\text{housing}} + (\Delta P_{\text{element}} * V_f)$$

Exercise:

Determine ΔP_{filter} at 15 gpm (57 L/min) for ST1KTZ10PY using 160 SUS (34 cSt) fluid.

Use the element pressure curve to determine $\Delta P_{\text{housing}}$ at 15 gpm. In this case, $\Delta P_{\text{housing}}$ is 1.5 psi (.10 bar) according to the graph for the ST element.

Use the element pressure curve to determine $\Delta P_{\text{element}}$ at 15 gpm. In this case, $\Delta P_{\text{element}}$ is .75 psi (.05 bar) according to the graph for the KZT10 element.

Because the viscosity in this sample is 160 SUS (34 cSt), we determine the Viscosity Factor (V_f) by dividing the Operating Fluid Viscosity with the Standard Viscosity of 150 SUS (32 cSt). To best determine your Operating Fluid Viscosity, please reference the chart in Appendix D.

Finally, the overall filter pressure differential, ΔP_{filter} , is calculated by adding $\Delta P_{\text{housing}}$ with the true element pressure differential, ($\Delta P_{\text{element}} * V_f$). The $\Delta P_{\text{element}}$ from the graph has to be multiplied by the viscosity factor to get the true pressure differential across the element.

Solution:

$\Delta P_{\text{housing}} = 1.5 \text{ psi } [.75 \text{ bar}] \mid \Delta P_{\text{element}} = .75 \text{ psi } [.05 \text{ bar}]$

$V_f = 160 \text{ SUS (34 cSt)} / 150 \text{ SUS (32 cSt)} = 1.07$

$\Delta P_{\text{filter}} = 1.5 \text{ psi} + (.75 \text{ psi} * 1.07) = 2.3 \text{ psi}$

OR

$\Delta P_{\text{filter}} = .10 \text{ bar} + (0.05 \text{ bar} * 1.07) = 0.15 \text{ bar}$

Pressure Drop Information Based on Flow Rate and Viscosity

ST

SKF3

TF-SKB

KF3-SKB

BFT-SKB

Note:

If your element is not graphed, use the following equation:
 $\Delta P_{\text{element}} = \text{Flow Rate} \times \Delta P_f$. Plug this variable into the overall pressure drop equation.

Ele.	ΔP	Ele.	ΔP	Ele.	ΔP
K3	0.25	KZW25	0.14	2KZW10	0.12
K10	0.09	2K3	0.12	2KZW25	0.07
K25	0.02	2K10	0.05	3K3	0.08
KAS3	0.10	2K25	0.01	3K10	0.03
KAS5	0.08	2KAS3	0.05	3K25	0.01
KAS10	0.05	2KAS5	0.04	3KAS3	0.03
KZX10	0.22	2KAS10	0.03	3KAS5	0.02
KZW1	0.43	2KZX10	0.11	3KAS10	0.02
KZW3	0.32	2KZW1	-	3KZX10	0.07
KZW5	0.28	2KZW3	0.16		
KZW10	0.23	2KZW5	0.14		

Filter Model Number Selection

How to Build a Valid Model Number for a Schroeder ST:

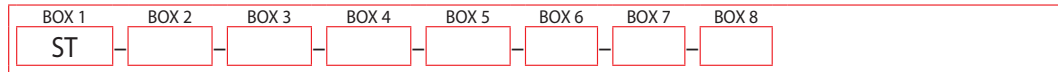

Example: NOTE: Only box 8 may contain more than one option

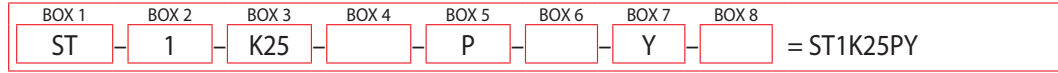

BOX 1	BOX 2	BOX 3			BOX 4
Filter Series	Number of Elements	Element Part Number			Seal Material
ST	1 2	K10 = K size 10 μ E media (cellulose) K25 = K size 25 μ E media (cellulose) KTZ3 = K size 3 μ Excellement [®] Z-Media [®] (synthetic) inside-out flow KTZ5 = K size 5 μ Excellement [®] Z-Media [®] (synthetic) inside-out flow KTZ10 = K size 10 μ Excellement [®] Z-Media [®] (synthetic) inside-out flow KTZ25 = K size 25 μ Excellement [®] Z-Media [®] (synthetic) inside-out flow			Omit = Buna N H = EPR W = Buna N H.5 = Skydrol [®] compatibility

BOX 5	BOX 6	BOX 7	BOX 8
Outlet Port	Optional Check Valve	Dirt Alarm [®] Options	Additional Options
P = 1½" NPTF PP = Dual 1½" NPTF S = SAE 24 SS = Dual SAE 24 B = ISO 228 G-1½" BB = ISO 228 G-1½"	Omit = None C = Check Valve	Omit = None Visual Y = Vacuum gauge YR = Vacuum gauge mounted on opposite side of standard location Electrical VS = Electrical Vacuum Switch VSR = Electrical Vacuum Switch mounted on opposite side of standard location VS1 = Heavy-Duty Vacuum Switch Heavy-Duty Vacuum VS1R = Switch on opposite side of standard location	Omit = None G2293 = Cork Gasket G547 = Two ½" gauge ports

NOTES:

Box 3. Replacement element part numbers are identical to contents of Boxes 3 and 4.

Box 4. For options H and W, all aluminum parts are anodized.
 H.5 seal designation includes the following: EPR seals, stainless steel wire mesh on elements, and light oil coating on housing exterior.
 Skydrol[®] is a registered trademark of Solutia Inc.

Box 6. See also "Accessories for Tank-Mounted Filters," page 299.