

Features and Benefits

- Patented mass transfer technology uses ambient air to optimize and control dewatering rates
- High Dewatering Rates and particulate removal in one system
- Simple Controls; RUN/DRAIN modes
- Reduce fluid recycling cost
- No expensive vacuum pump to service and replace
- Compact, efficient footprint
- Remove free and dissolved water
- Highly effective in low and high humidity environments

Part of the Schroeder Industries 2030 Initiative

2.0 gpm
7.6 L/min

Water contamination in hydraulic systems can severely reduce the life of hydraulic systems and fluids. The Triton Dehydration Station® is designed to eliminate 100% of free and up to 90% of dissolved water from small reservoirs, barrels, and gear boxes. Using a patented mass transfer process, the Triton Dehydration Station® efficiently removes water and particulate contamination quickly in all environments. A proprietary design reduces aeration of free and entrained gases of returned fluid. The unit was designed to be extremely portable using the optional cart to access tight areas.

The Triton Dehydration Station® uses patented mass transfer dewatering technology. Ambient air is conditioned to increase its water holding capability before injecting to the reaction chamber. Fluid is equally distributed and cascaded down through reticulated media and the conditioned air stream. Water is transformed to water vapor and is expelled from the unit as a moist air stream. The relative humidity of the incoming fluid is continually monitored by an integral AS1000 and displayed real-time on the control panel.

Description

Principle of Operation

Specifications

Dimensions:	45.2"(H) x 36.7"(W) x 20.3"(D)
Dry Mass:	295 lbs (134 kg)
Inlet Connections:	1" SAE
Outlet Connections:	1" SAE
Flow Rate:	120 gallons/hour or 2.0 gpm
Permissible Inlet Pressure Range:	-5.8 psig (-0.4 bar) to 32 psia (2.2 bar)
Max. Permissible Outlet Pressure:	75 psig (5 bar)
Fluid Service Temperature:	100° F to 150°F (40°C to 65.5°C)
Fluid Viscosity:	70- 1000 SUS (13 - 215 cSt), Explosion-proof: 500 SUS maximum
Power Supply:	110 VAC, 60 Hz, 12 amp
Attainable Water Content:	< 50 ppm
Relative Humidity Display:	Standard, 0-99% Range
Construction:	Reaction Vessel: Stainless Steel Seals: Viton®
Protection Class:	NEMA 2

Media	Filter Rating	DHC (gm)
Z1	β 4.2 _(C) ≥1000	55
Z3	β 4.8 _(C) ≥1000	57
Z5	β 6.3 _(C) ≥1000	62
Z10	β 10 _(C) ≥1000	52
Z25	β 24 _(C) ≥1000	48

Element Performance

- CS 1000
- CS 1939
- CSI-C-11
- HY-TRAX®
- RBSA
- CSM
- FCU
- MCS
- AS
- SMU
- CTU
- EPK
- Trouble Check Plus
- HMG2500
- HMG4000
- ET-100-6
- HTB
- RFSA
- HFS-BC
- HFS-15
- MFD-BC
- MFS, MFD
- HY-TRAX® Retrofit System
- MFD-MV
- MFS-HV
- AMS, AMD
- FS
- AMFS
- KLS, KLD
- MCO
- AKS, AKD
- LSN, LSA, LSW
- X Series
- OLF Compact
- OLF
- OLF-P
- NxTM
- VEU-F
- VMU
- IXU
- Triton-A**
- Triton-E
- NAV
- SVD01
- OX5
- Appendix

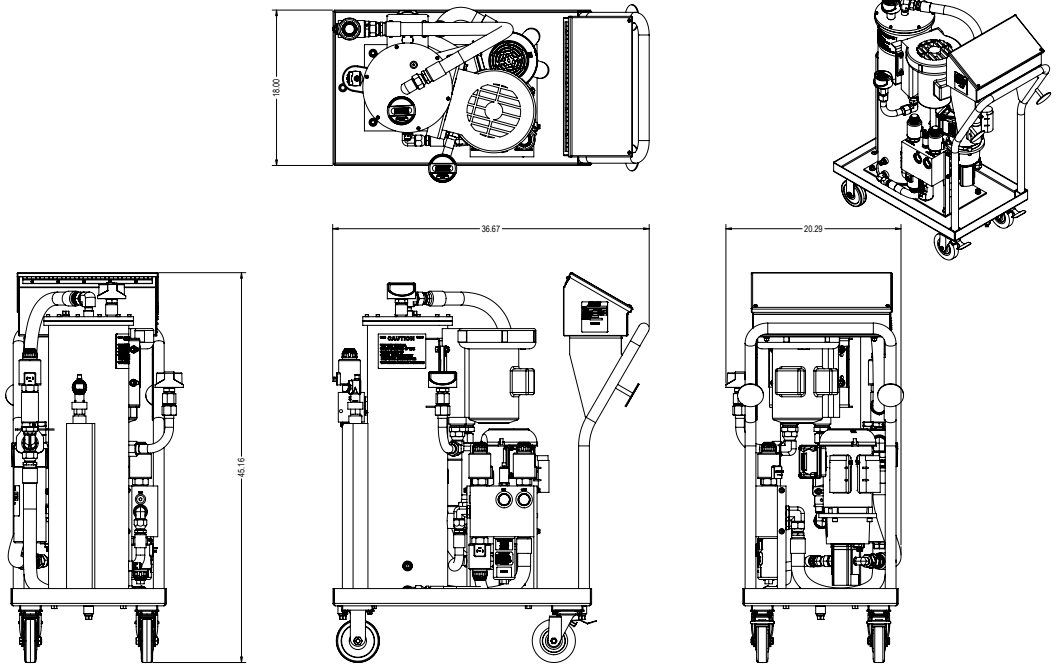

TDSAVMABxx1

Dimensions in inches.

Model Number Selection

How to Build a Valid Model Number for a Schroeder Triton-A:

BOX 1 BOX 2 BOX 3 BOX 4 BOX 5 BOX 6 BOX 7 BOX 8
 TDS [] [] [] [] [] [] [] []

Example: NOTE: One option per box

BOX 1 BOX 2 BOX 3 BOX 4 BOX 5 BOX 6 BOX 7 BOX 8
 TDS A V M A B 05 1 = TDSAVMAB051

BOX 1	BOX 2	BOX 3	BOX 4	BOX 5
Model	Flow Rate	Seals	Mobility	Voltage
TDS	A = 2.0 gpm	V = Viton®	S = Stationary M = Caster Base	A = 110V/60 Hz/ 1 Phase B = 220V/60 HZ/ 1 Phase C = 220V/50 Hz/ 1 Phase

BOX 6	BOX 7	BOX 8
Air Source	Media	Option
B = Integral Blower C = Compressed Air (customer must supply clean, dry air)	01 03 05 10 25	X = Class 1, Div 2 explosion-proof 1 = Cart Version Y = Built with CSA approved components (requires CSA inspection on-site)

For replacement element part numbers, please see "Appendix Section - Replacement Elements" of this catalog.